

ENERGIZER 312 size - **Mercury Free**

ZnAir

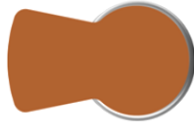

General Information

Chemical System:	Zinc Air (Zn/O ₂)
Tab Color:	Brown
Designation:	ANSI-7002ZD, IEC-PR41
Nominal Voltage:	1.45 Volts
Typical Capacity:	180 mAh (to 1.05 volts) (IEC-STD at 10/2 mA at 21°C)
Typical Weight:	0.5 grams (0.02 oz.)
Typical Volume:	0.2 cubic centimeters (0.01 cubic inch)

Industry Standard Dimensions

mm (inches)

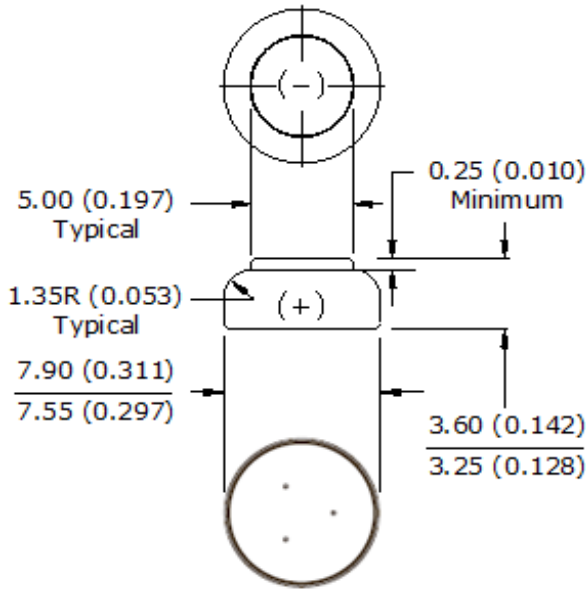

Typical Discharge Characteristics

ANSI / IEC Industry Standards / Standard Test Protocol
(10/2 mA .1S/1H59M 59.9S 12H at 21C)

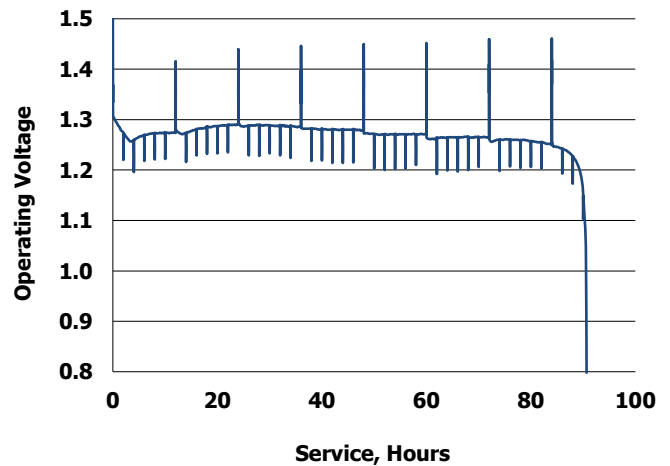

Typical Discharge Characteristics

ANSI/IEC Industry Standards / Wireless Streaming Protocol
(5mA 15 min / 2mA 45 min 12 H cycle at 21C)

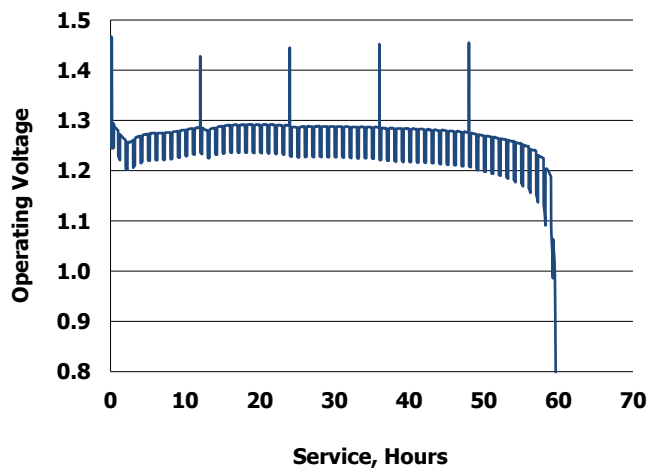

Important Notice

This datasheet contains typical information specific to products manufactured at the time of its publication.
Contents herein do not constitute a warranty and are for reference only.